



AMERICAN JOURNAL OF INNOVATION IN SCIENCE AND ENGINEERING (AJISE)

ISSN: 2158-7205 (ONLINE)

VOLUME 3 ISSUE 3 (2024)

PUBLISHED BY

E-PALLI PUBLISHERS, DELAWARE, USA

Enhancing SCR Switching Performance of Gas Drilling Rigs in Humid Climates Using Sensor and Relay-Based Control Circuitry with Failure Prevention and Warning Feedback Methodology

Muhammad Shefaul Islam^{1*}, Md. Samin Safayat Islam², Asif Jaman²

Article Information

Received: August 25, 2024

Accepted: September 27, 2024

Published: October 01, 2024

Keywords

Humidity Impact, Power Control System, Power Supply Reliability, SCR Application, SCR Failure

ABSTRACT

Bangladesh's economic ascent, marked by robust GDP growth fueled by investments across diverse industries, hinges significantly on the deployment of modern automatic process control technologies. Among these technologies, silicon-controlled rectifiers (SCRs) play a pivotal role, particularly in critical sectors such as petroleum, chemicals, and manufacturing. However, the nation's tropical climate, with its soaring humidity levels, presents a formidable challenge to the reliability of SCRs. This research endeavors to unravel the intricate interplay between humidity and SCRs performance within Bangladesh's industrial landscape. The primary objectives encompass the prevention of SCR failure, enhancement of circuitry performance, and development of a humidity variation warning system. Strategies will be explored to mitigate humidity-induced issues and improve overall SCR reliability based on real-time data collected from the oil drilling plants. Additionally, innovative approaches will be devised to bolster circuitry performance, addressing the unique challenges posed by humid environments. Furthermore, a sophisticated warning system will be engineered to detect fluctuations in humidity levels, enabling proactive intervention to avert SCR failures. By addressing these challenges head-on, this research seeks to fortify Bangladesh's industrial ecosystem against the vagaries of humidity, fostering resilience, sustainability, and productivity in the face of dynamic environmental conditions in power supply system.

INTRODUCTION

In recent years, Bangladesh has experienced a commendable economic upswing, marked by a consistent annual GDP growth rate of 7% to 8%. This robust economic trajectory owes its momentum to substantial investments, both domestic and foreign, channelling into a diverse array of industries (Mamun & Kabir, 2023). These industries, characterized by their adoption of modern automatic process control technologies, prominently feature power semiconductor devices like Silicon-Controlled Rectifiers (SCRs). SCRs possess voltage clamping capabilities that enhance the reliability of power supply systems, ensuring stable voltage supply without fluctuations. These SCR devices serve as linchpins in critical sectors such as petroleum (gas and oil drilling rigs), chemicals, food processing, fertilizers, and various manufacturing domains, contributing indispensably to the overall fabric of the country's industrial landscape (Wang *et al.*, 2023). However, amidst the economic prosperity, challenges have emerged, casting shadows on the reliability and performance of SCRs. The tropical climate of Bangladesh, where humidity levels can surge up to 95% during the summer, poses a significant risk to the optimal functioning of SCRs. The repercussions include critical failures during pivotal phases such as startup and commissioning, prompting a pressing need for comprehensive exploration and solutions. This research plunges into the intricate challenges posed

by humidity on SCRs within the specific context of Bangladeshi industries. The overarching objective is to provide not only valuable insights but also practical solutions to fortify the industrial ecosystem against the nuanced challenges associated with SCR reliability in humid environments. By addressing these concerns head-on, the aspiration is to cultivate greater industrial resilience, sustainability, and productivity, thereby steering the industrial landscape towards a robust and adaptive future in the face of dynamic environmental conditions. Over the past few decades, Bengal Basin has seen the discovery of 29 gas fields among which 20 of them are in production. Since the inception of natural gas exploration in Bangladesh in 1955, the total gas initially in place (GIIP) has been estimated at 39.0 trillion cubic feet (TCF), with an estimated total recoverable gas reserve (Proved plus probable) of 27.12 TCF (Hassan Shetol *et al.*, 2019). As of December 2023, approximately 20.33 TCF of gas has been extracted (Energy and Mineral Resources Division, 2022). The natural gas production and distribution sector is a pioneering element of the national economic structure. That's why it's immensely important to run the facilities of gas exploration and drilling rigs without any disturbances. This research focuses on solving the discontinuity and interruption in the gas drilling rigs of Sylhet Gas Field Company Ltd. due to the failure of DSU units which are in actual practice a combined set up of SCRs helping to ensure continuous power supply.

¹ Bangladesh Petroleum Exploration & Production Company Limited, Dhaka, Bangladesh

² Rajshahi University of Engineering & Technology, Rajshahi, Bangladesh

* Corresponding author's e-mail: shefaul@gmail.com

Problem Statement

Water vapor, known for its electrically conductive and corrosive nature, poses a significant challenge to electrical circuits, particularly those employing Silicon-Controlled Rectifiers (SCRs). In industrial SCR modules, housed in plastic enclosures with cured silicone-based gel insulation, the permeation of atmospheric gases, including water vapor, through openings, raises concerns. The prescribed climatic class 3K3, as outlined in IEC 60721-3-3, specifies a relative humidity range of 5% to 85% without condensation. The lack of hermetic sealing in SCR modules can lead to water vapor and liquid condensation, affecting SCR components and compromising their reliability. The observed incidents of SCR failures in Bangladesh, especially during start-up and commissioning in high-humidity conditions exceeding 95%, underscore the need to address the adverse effects of humidity on SCR performance. During startups, high humidity amplifies the impact of transient voltage spikes on the SCR, heightening the risk of component failure. Transients are more prone to cause unwanted SCR conduction in the presence of moisture, resulting in short circuits or premature triggering. Furthermore,

moisture-induced changes in the electric field distribution can render the SCR more vulnerable to voltage surge damage, reducing its reliability under transient situations. The impact includes compromised voltage withstand of insulation materials, reduced blocking voltage due to increased moisture conductivity, and disruptions in electric field lines at semiconductor edges, ultimately leading to SCR failure or damage. To tackle these challenges, the research aims to explore preventive measures, enhance SCR circuitry performance, and develop a warning system to detect humidity variations and mitigate their impact on SCR modules, particularly in regions with high humidity levels.

Geographical Location and Survey Data

Embedded within the north-eastern region of Bangladesh, Sylhet Division stands as a pivotal administrative centre, richly endowed with natural and mineral resources. Its strategic location near Assam, Meghalaya, and Tripura in India positions it as a significant cross-border nexus. Notably, Sylhet Division boasts a distinct geographical characteristic — it is enveloped by mountains on both its northern and southern peripheries.

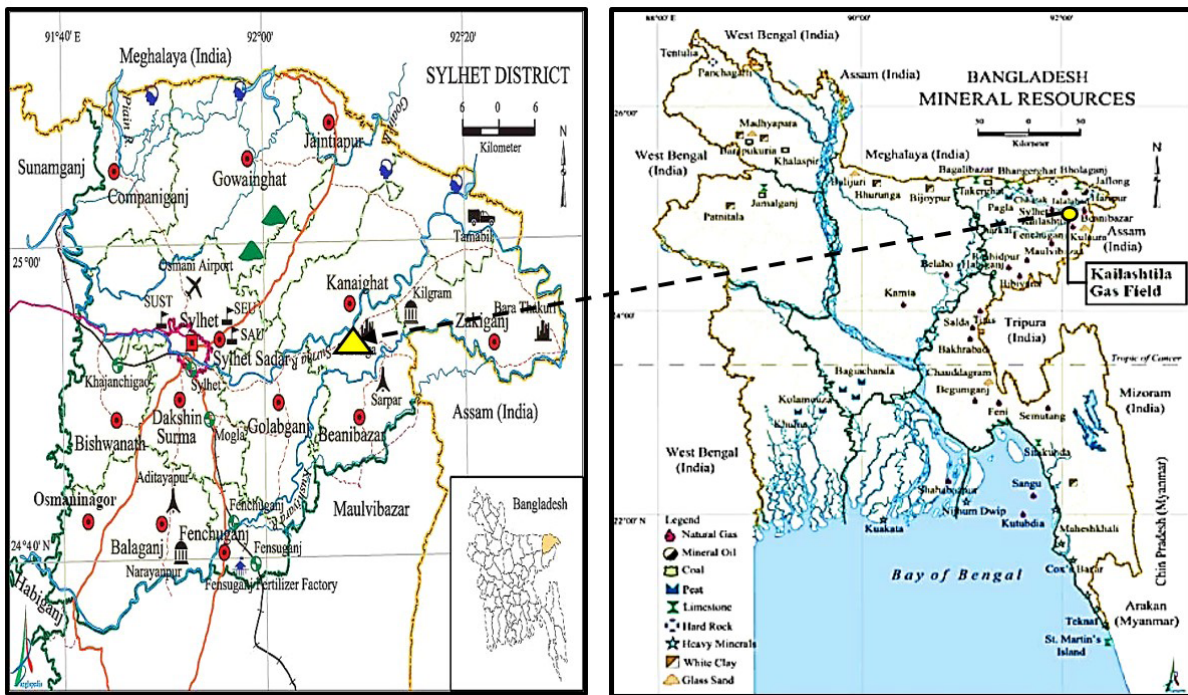

Figure 1: Location of the study area

This unique topographical feature not only adds to the division’s scenic allure but also shapes its ecological and developmental landscape, warranting scholarly attention and exploration within the context of regional studies

and resource management. The required data of hourly relative humidity of the test site were collected from the Kailashtila gas field in Sylhet which shown by the given co-ordinate (24.86, 92.025) in the map, shown in figure.

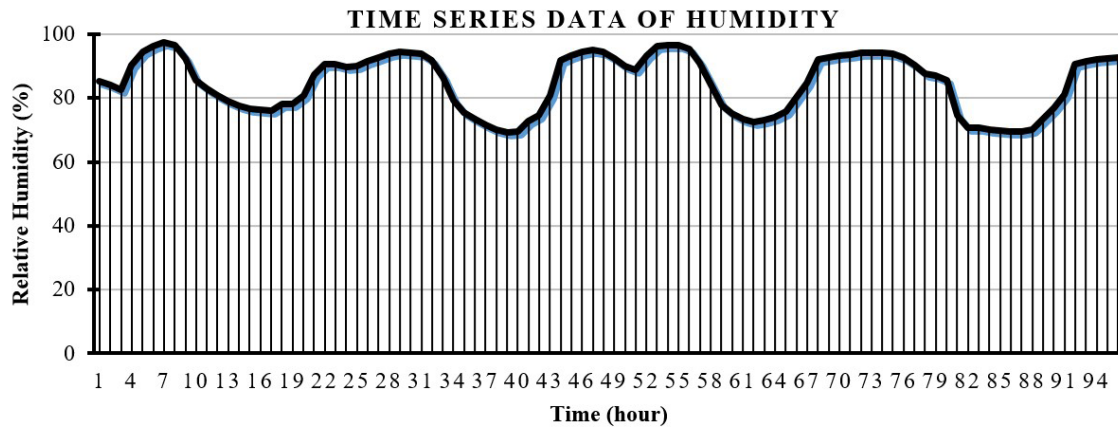

Figure 2: Survey data collected from the study area for 96 hours

Objectives

The objectives of the research paper are as follows:

Prevention of SCR Failure

Investigating strategies and measures to prevent the failure of Silicon-Controlled Rectifiers (SCRs), particularly focusing on factors related to humidity-induced issues.

Performance Enhancement of SCR Circuitry

Exploring methods to enhance the overall performance and reliability of SCR circuitry, considering aspects such as efficiency, durability, and resistance to environmental factors, with a particular emphasis on addressing challenges posed by humidity.

Development of Humidity Variation Warning System

Designing and implementing a warning system to detect and signal humidity variations that may adversely affect SCR components. This objective aims to provide an early indication of environmental conditions that could potentially lead to SCR failure, allowing for proactive measures to be taken.

MATERIALS AND METHODS

Control Methodology

The impact of humidity is the most whenever the SCR is in starting conditions. During switching conditions brief surge or spike in the electrical voltage that surpasses a circuit's usual operating voltage can be observed frequently referred as transients. Other than switching these situations may occur due to lightning strikes, powerline disturbances which can result to tripping and component damage. If the humidity level hits 85%, condensation occurs within the SCR, rendering it unreliable. The proposed system constantly monitors if humidity exceeds 85% and the SCR is in starting or running mode. During the start-up state, it won't allow the system to begin until the humidity falls below 85%. During this time dehumidifying systems are kept running. Whenever the system is in running condition the effect of moisture is less severe. In this condition, if the humidity reaches 90%, a warning message will be sent to the authorities.

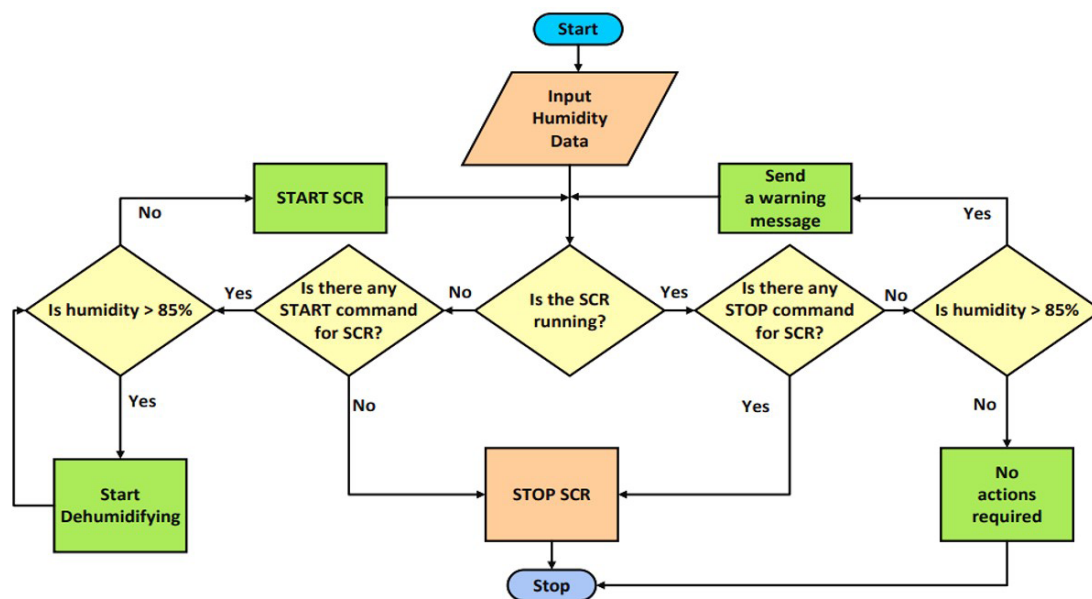

Figure 3: Control Methodology of the designed system

System Architecture

A digital hygrometer is utilized to implement a safety lock circuit for the SCR. In automated industries equipment like SCR is controlled via signals from PLC (Programmable logic controller) or manual operators. These signals are intercepted by the controller's relay terminal. If excessive humidity is detected, the controller triggers the relay, preventing SCR activation until conditions improve. Advanced SCR systems may receive digital start/stop signals, requiring the SCR's power

supply to be locked via a control circuit until humidity levels are acceptable. This ensures SCR reliability and performance in industrial settings. The whole process is shown in the figure 4 where the start stop signal is coming from the operator or PLC and it is interpreted by the DHC (Digital Hygrometer controller). The DHC takes humidity into consideration which helps it decide whether the SCR should start or not. Then the signal is sent to the SCR providing a secured operation for the SCR.

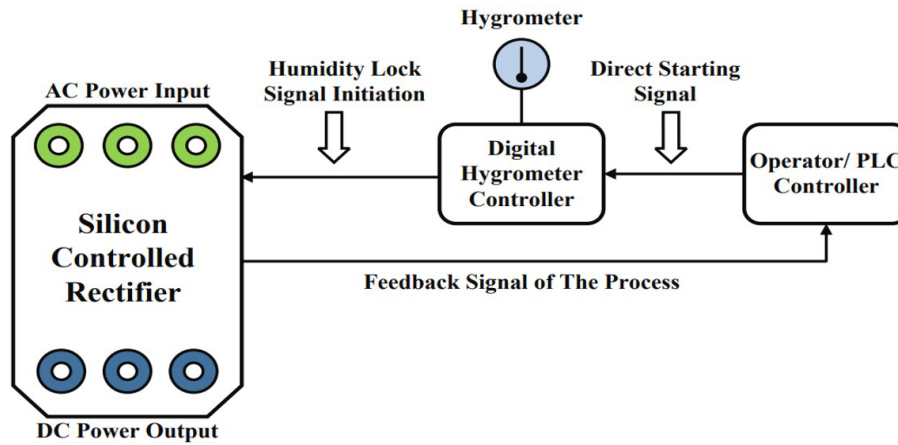

Figure 4: Integrated System Architecture of the control unit

Simulation Process of the System

The simulation of the entire system is conducted within the MATLAB environment. Six thyristors are employed to emulate a three-phase rectifier module. The humidity data utilized for simulation is sourced from a dataset obtained from a gas extraction site located in Sylhet. It uses a

MATLAB function block instead of a Programmable Logic Controller (PLC) which accepts humidity levels and start/stop signals as inputs. The output signal of the MATLAB function block governs the operation of circuit breakers, facilitating automated control of power delivery within the SCR system.

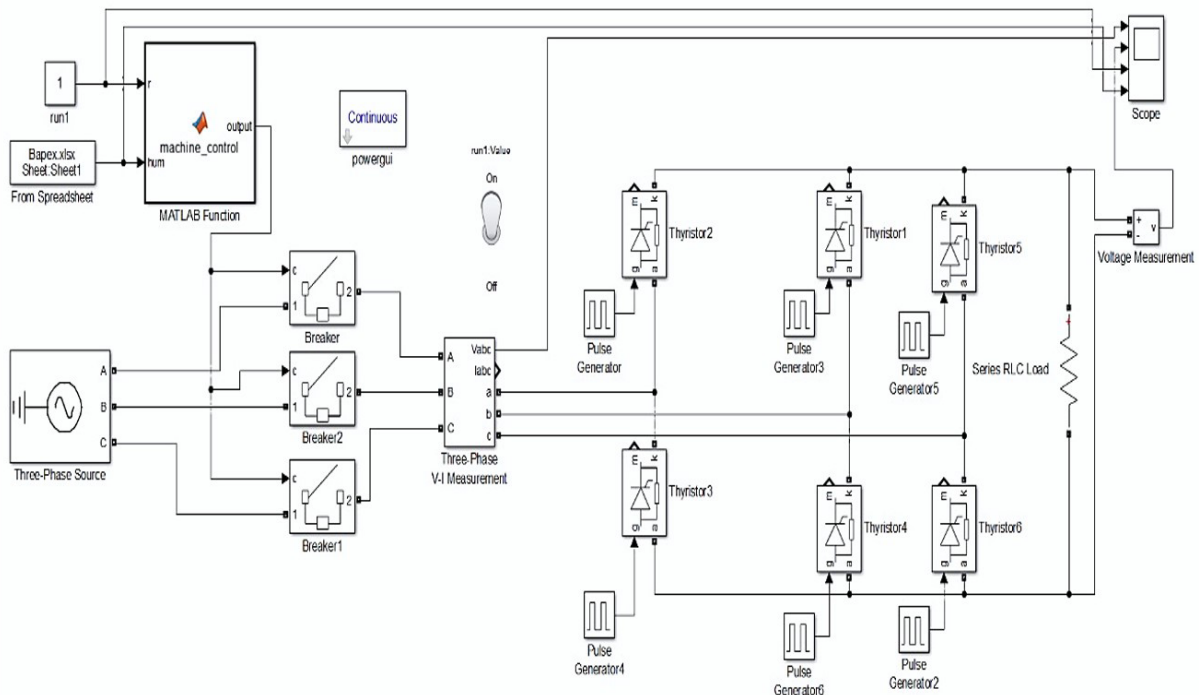

Figure 5: Simulation process conducted in MATLAB Simulink environment

Mathematical Expressions and Symbols

The MATLAB function block takes humidity from our gathered dataset directly and considers the start/stop command which is given by the toggle switch. From here the MATLAB function block works as a PLC and decides whether the power supply should be given to the rectifier circuit or not. The MATLAB function block output controls the breakers which can disrupt the power supply to the rectifier circuit. 6 thyristors are utilized to construct the rectifier unit where each thyristor is given a gate pulse firing at a different angle. For this purpose, each pulse generator is given a time-based pulse type. To fire at a specific angle, the phase delay of the pulse generator is controlled using the equation below:

$$\text{Phase delay at } x^\circ = ((x^\circ) / (360^\circ)) \times 1 / f \quad (1)$$

Where:

- x° is the angle the thyristor needs to be fired at
- f is the frequency of the system which is 50Hz in this case

The thyristor1, thyristor2, thyristor3, thyristor4, thyristor5, thyristor6 are fired respectively at $0^\circ, 120^\circ, 240^\circ, 180^\circ, 300^\circ, 60^\circ$.

RESULTS AND DISCUSSION

As shown in figure 6, the SCR produces an 800V DC output when it functions normally at a frequency of 50 Hz and an input voltage of 600V (rms). Owing to the absence of smoothing capacitors and additional filtering circuits, the resultant output manifests as pulsating DC. Time is represented by the X-axis in all of the graphical representations, and simulations are run for 100 milliseconds.

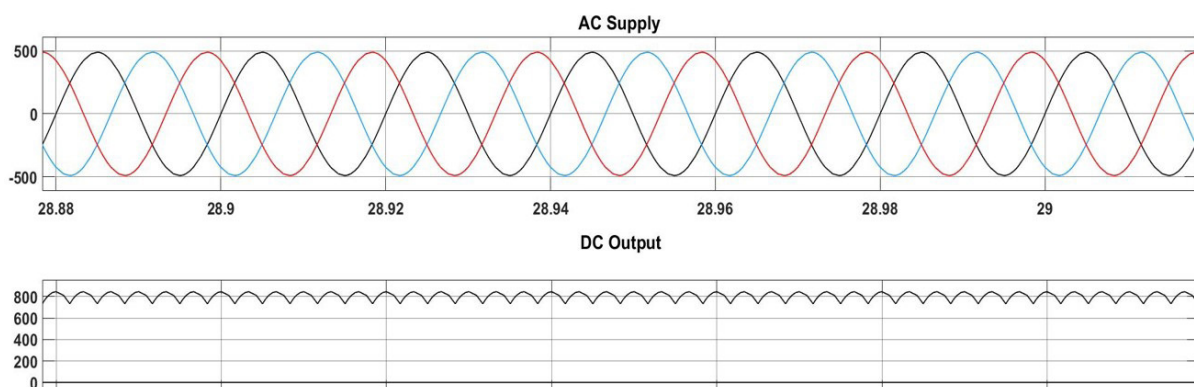

Figure 6: Output Signal from the designed system

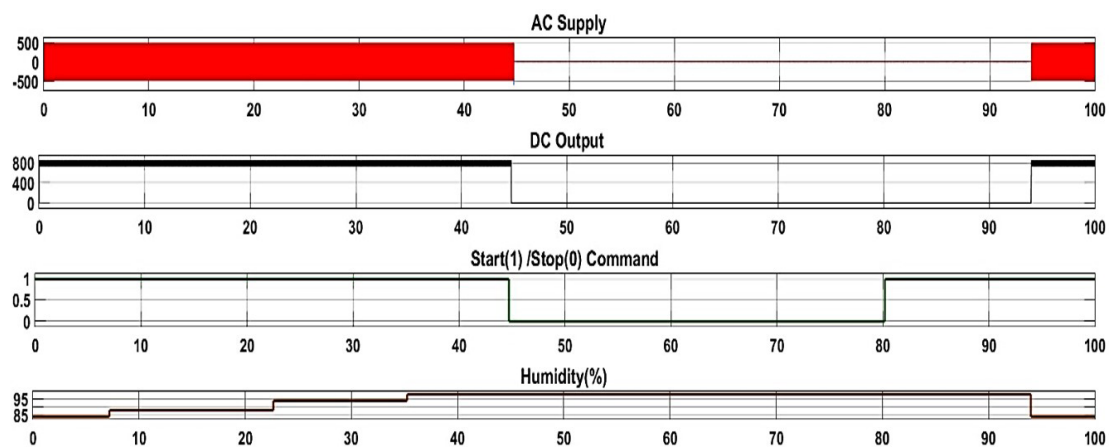

Figure 7: Analysis of system effectiveness

In the figure no. 7, the proposed system's effectiveness in mitigating the impact of humidity is evident, particularly when the SCR is initiated from a standstill state. Illustrated in Figure 2, the SCR initially operates under running conditions while the humidity gradually escalates from 84% to 98% seamlessly. It is noteworthy that the proposed method effectively handles the humidity spike, issuing a warning through the MATLAB command prompt as soon as the 90% humidity threshold is exceeded. Then, when a stop instruction is sent shortly before the 50 ms

threshold, the SCR stops working, but the humidity level stays high at about 98%. But a problem arises when trying to restart at the 80 ms mark since the excessive humidity levels prevent the SCR from restarting. Its ability to prevent SCR initiation until humidity levels drop into the specified range demonstrates the effectiveness of the technology. As we get closer to the 95 ms threshold, the humidity drops, which helps the SCR reactivate. This technique successfully protects equipment from humidity-related SCR system failures.

CONCLUSION

The research delved into the complex challenges posed by humidity on Silicon-Controlled Rectifiers (SCRs) in industrial settings, particularly in regions like Bangladesh where humidity levels often exceed 95%. Through a meticulous exploration of preventive strategies, performance enhancement measures, and the development of a humidity variation warning system, significant insights and advancements have been achieved. The system's ability to avoid transient voltage spikes is crucial because it protects the SCR from abrupt surges that may otherwise cause damage or premature triggering. This is achieved by detecting high humidity alerts and switching situations, which efficiently divert and dissipate excess energy away from the SCR, safeguarding it during crucial startup stages. The results obtained through MATLAB Simulink simulations provided valuable validation of the proposed methodologies. The designed system effectively produced an 800V DC output under normal operating conditions, demonstrating its functionality and reliability. Moreover, the analysis revealed the system's effectiveness in mitigating the adverse effects of humidity, particularly during SCR startup and operation in high-humidity environments. By issuing timely warnings and preventing SCR initiation until humidity levels fall within acceptable ranges, the developed technology proves instrumental in safeguarding equipment from humidity-induced failures. Overall, this research contributes to the broader discourse on SCR reliability in humid environments, offering practical solutions and insights for industry practitioners and researchers alike. The findings underscore the importance of proactive measures in addressing humidity-related challenges and highlight the potential of innovative technologies in enhancing industrial resilience and sustainability.

Acknowledgements

We express our profound gratitude to the Bangladesh Petroleum Exploration and Production Company Limited (BAPEX) for authorizing this research and providing essential support throughout the project. We are especially thankful to the engineers and maintenance workers at Kailashtila Gas Field, Sylhet, who not only facilitated our access to necessary survey data but also shared their invaluable expertise on the control system and operational methods of the facility. Their assistance has been instrumental in the successful completion of our research. We acknowledge their contributions with great appreciation.

REFERENCES

- Energy and Mineral Resources Division, B. (2022). *Annual report on gas production, distribution and consumption*. http://www.hcu.org.bd/sites/default/files/files/hcu.portal.gov.bd/publications/ef31dcff_c7e7_4674_a1fd_2df47241ee8a/2023-03-14-08-01-513b4590a8a542b9668c1ce6b872711e.pdf
- Hassan Shetol, M., Moklesur Rahman, M., Sarder, R., Ismail Hossain, M., & Kabir Riday, F. (2019). Present status of Bangladesh gas fields and future development: A review. *Journal of Natural Gas Geoscience*, 4(6), 347–354. <https://doi.org/10.1016/j.jnggs.2019.10.005>
- Mamun, A., & Kabir, M. H. M. I. (2023). The remittance, foreign direct investment, export, and economic growth in Bangladesh: A time series analysis. *Arab Economic and Business Journal*, 15(1). <https://doi.org/10.38039/2214-4625.1022>
- Wang, Y., Liu, Y., Zhong, Z., Jin, X., Peng, Y., Luo, J., & Yang, J. (2023). Gate-controlled silicon controlled rectifier with adjustable clamping voltage using a photoelectric mechanism. *Optics Express*, 31(1), 651. <https://doi.org/10.1364/OE.475142>