



# AMERICAN JOURNAL OF INNOVATION IN SCIENCE AND ENGINEERING (AJISE)

ISSN: 2158-7205 (ONLINE)

VOLUME 2 ISSUE 2(2023)

PUBLISHED BY  
E-PALLI PUBLISHERS, DELAWARE, USA

## Design and Fabrication of Shoe/Slippers Sanitizing Ramp

Jimcel P. Pecaso<sup>1\*</sup>, Robert P. Nueles<sup>1</sup>

### Article Information

**Received:** May 27, 2023**Accepted:** July 22, 2023**Published:** August 05, 2023

### Keywords

*Covid19, Innovative Design, Sanitizing Ramp, Research and Development, Pandemic, Sanitation*

### ABSTRACT

This paper describes the design and development of a low-cost shoe and slippers sanitizing ramp and proposes an innovative design using a conventional switching unit to operate the device. User acceptance, technical performance, and cost analysis are presented through surveys and testing. The project development study was realized as a disinfecting device by modification of a manually-operated sanitizing ramp. It uses a 12volt converter-charger and or storage battery as a pump power source, 20-70 kg/m working pressure pump unit, 0.10mm diameter with one-hole brass misting nozzles and conventional switches mounted in the 12kg wheeled main frame. The technical evaluation result shows that misting nozzle sprays are limited to 10-20cc/min. Regarding cost, it is just a portion of the cost compared to the commercially available and electronically-operated model. The developed sanitizing ramp offers an option for users who cannot pay for or buy the commercially available one.

### INTRODUCTION

With the inevitable spread of the Coronavirus 2019 (COVID19) disease, not just in the Philippines but all over the world, we were confronted with the greatest challenge of our time. Only the wealthiest nations are capable of undertaking research to help uncover a means to resist this virus, which has triggered a pandemic that has the entire cosmos in a tizzy.

According to Dhananjay, 2020, who conducted a study related to COVID-19 virus, which is presumed to originate in Wuhan, China, has infected millions of individuals globally since December 2019. The World Health Organization (WHO) proclaimed the COVID-19 virus a pandemic and a global health emergency in March 2020. Tens of thousands of people die every day due to the exponentially growing COVID-19 viral outbreak. Numerous international health and detective agencies are still looking into the virus's purported source in Wuhan, China. Humans can spread this virus to other humans.

Portable devices, such as cold foggers, can serve as sanitizing machines. The sanitizing units spray disinfectant into the air in a fine mist that lands on surfaces and kills bacteria and viruses. By using sanitizing moisture, humans are able to reach areas they cannot get or may miss when hand-cleaning. With the emergence of Covid19, sanitizing is a means to lower the number of germs to a safe level. What is considered a safe level depends on governments' public health standards and or requirements at a workplace, school, and other public places. To address the silent sources of Covid19, proponents of this line of project study focused on the development of improved sanitizing machines for public use.

### LITERATURE REVIEW

In Nigeria, Yusuf, *et al.* (2022) demonstrated a successful

implementation of determining the nearest healthcare facility in order to make testing and vaccination easier and more accessible. The community became aware of and improved their participation in COVID-19 testing and vaccination as a result.

In their study, Boyce *et al.* (2016) noted how experts generally concur that thorough cleaning and disinfection of environmental surfaces are crucial components of successful infection prevention strategies. They reaffirmed the need for more research to clarify the relative benefits and drawbacks of using microfiber, cotton cloths, and spun-lace non-woven disposable wipes to apply surface disinfectants. In their study, Rutala *et al.* (2013) noted that polluted ambient surfaces represent a significant potential source for the spread of infections linked to the provision of healthcare. Additionally, numerous interventions have recently been proven to be successful in enhancing surface cleaning and disinfection. This review looked at the data showing that enhancing environmental sanitation can lower illnesses linked to healthcare.

It was also known in a circulating reading material that household cleaner containing soap or detergent reduces the number of germs on surfaces and decreases risk of infection from surfaces. In most situations, therefore, cleaning alone removes most virus particles on surfaces. Disinfection to reduce transmission of COVID-19 at home is likely not needed unless someone in your home is sick or if someone who is positive for COVID-19 has been at home within the last 24 hours. On the other hand, not everyone can stay at home during this pandemic. People commute to work and visit stores to purchase the food, medications, and other necessities they require. People try to keep themselves secure and careful in the event of a pandemic. Face shields, masks, and disinfectants are utilized to fight this pandemic. Additionally, cleaning your hands is a crucial step in the procedure. Medical workers

<sup>1</sup> Partido State University, Philippines

\* Corresponding author's e-mail: [jimcel\\_psu@yahoo.com](mailto:jimcel_psu@yahoo.com)

change out of their shoes and wash them afterward since footwear can transmit viruses just like clothing does. The health certifying authority has decided that a number of infectious illnesses and bacteria can be discovered on footwear. Mondal *et. al.*, 2022 finds that footwear is one of the probable causes of contamination and possible mover of the virus, especially if it touches an infected place. Since most footwear is made of leather, rubber, and plastic, the virus can live on these for many days at room temperature. Even footwear can be a breeding ground for bacteria and viruses as it comes in contact with dirt and germs more than anything else. Their paper, a smart device for disinfecting footwear has been proposed for crowded premises. The sensing device automatically sense the visitor's presence at the entrance and will disinfect his footwear by spraying disinfecting agent underneath the footwear or foot. This disinfecting station will allow visitors to disinfect their footwear without stopping and will ensure effecting sanitization of the entire sole

even if the sole has deep flex grooves or high heels. Rashida, *et al.* (2017) found a significant bioburden of microorganisms on shoe soles. Studies have shown that either direct or indirect transmission paths might result in the colonization of patients with microbiological infections from shoe soles. Shoes and slippers are one of the primary points of contact in public spaces, according to Eskie's research from 2020. People thus face the risk of introducing germs like viruses and other harmful ones into their houses. E. Allen Al, 2010, said in their study that employing disposable shoe coverings or disinfectant mats may help lower the bacterial burden on the flooring of rodent holding rooms. Also, a research team discovered virus on floors, computer mice, trash cans, sickbed handrails and doorknobs. What is most revealing in their study is that half of the medical teams' shoes tested positive for the virus. So, using a sanitizing mat (figure 1.) to disinfect shoes at the door help further prevent the spread of COVID-19.



**Figure 1:** Sanitizing mat/trays used for shoe/slippers.

Also, there are commercially available sanitizing ramps that use ultra-violet rays as means of sanitizing shoes is shown in Figure 2.



**Figure 2:** Images of commercially available shoe sanitizing stations. (<https://rb.gy/jiy0g>)

In their article from 2021, Sahu *et al.* describe a shoe-cleaning device that uses an IR sensor and a micro-controller. The system's primary goal is to sanitize the shoes by flinging liquid sanitizer. The device resembles a shoe mat. Under the mat was a sanitizer sprayer. When the device detects the shoes, it sprays liquid fluid. To detect the presence of shoes or persons, an IR sensor array is utilized. Breaking the chain of community transmission and the growing concern regarding disinfection of surfaces, including clothes and shoes is one of the best preventative measures against COVID-19, therefore,

it was considered urgent to introduce a portable smart shoe/slipper disinfecting ramp, though conventional will be of help in controlling spread of virus. The goal of this study is to present and deal with application of combined mechanical and electrical actuators in the improved sanitizing ramp. This aimed towards fabricating a sanitizing device using conventional drives and made comparable with the existing shoe mat with disinfectants. Considering the above cited discussions on COVID-19 as the virus causing SARS transmitted by direct and indirect contact with respiratory droplets, the proponents

endeavored to design, fabricate, test, revise and evaluate a shoe/slipper sanitizing ramp using locally available materials.

**Objectives**

**General Objective:**

Design and develop a shoe/slipper sanitizing ramp.

**Specific objectives**

1. Develop a shoe/slipper sanitizing device out of locally available materials.
2. Analyze the capacity of discharging fluid concerning weight and cost using a converter charger/battery as pump power source.
3. Determine the acceptability of the device in terms of effectiveness and efficiency.
4. Consider design revisions based on encountered problems.

**METHODOLOGIES**

In this study, Research and Development (R&D) procedures were utilized since the output can be applied as primary caution in fronting the existing global pandemic.

The sanitizing ramp was made useful to basic disinfection and sole sanitization. The descriptive-development method of assessing the device's efficiency support the validity of the study.

The fabrication of the device was conducted at a common welding shop in Goa, Camarines Sur.

A 2-wheeled frame assembly in a pre-determined size was developed using locally available materials: stainless sheet, galvanized pipe, 12V pump motor, canister, misting nozzles, piping, hose & fittings, converter/charger and other relative accessories.

It was designed as a shoe and slippers sanitizing ramp with the following components:

1. Main frame- include and install all the important parts of the sanitizing ramp.
2. Pump motor-most important part of the device to supply disinfecting mixture to the misting nozzles.
3. Converter/charger- serve as power source to energize the pump motor
4. Sanitizing fluid storage- canister for recommended sanitizing liquid.
5. Misting nozzles- provide and deliver the disinfecting



**Figure 3:** The shoe/slippers sanitizing ramp.

mixture to the shoe or slippers

6. Rubber caster-for easy transport of the device
7. Waste bin- stores disinfecting mixture waste.

In the device, additional mounting frame was initially included intended for the ultra-violet lamp (optional) to serve as back-up if disinfecting chemicals are exhausted and not available for use but not part of the previously proposed design.

The fabrication process includes the following technical development stages:

**Designing**

Planning of the different steps was followed at this stage prior to the development of the project. The pre-determined size and shape of the device was trailed

specifically on the mainframe as shown in Figure 3. The structural plan was likewise completed at this juncture.

**Pre-construction**

The bill of materials was prepared and procured before the construction began.

**Constructing**

This all involve the process and system construction of cutting, fabricating,welding, and aligning of frame wherein all specified components was installed and interconnected.

After the fabrication, actual testing was done to determine some emerging deficiencies. This includes a visual inspection of the parts and evaluation of its operation.

**Testing**

There was a validation try-out of the sanitizing device and respondent were obliged to comments on the acceptability in terms of effectiveness and efficiency.

**Revising**

Modifications and or revisions was adopted to solve machine defects and problems encountered. After the try-out, the discharge expressed as mass flow rate and weight flow rate can be computed. Other factors such as cost-benefit-analysis, physical specifications and requirements were also considered in the evaluation of the sanitizing ramp. The use of literature review protocols by searching potentially available and relevant literature also enhances assessment discussions.

**RESULT AND DISCUSSION**

**On Sanitization**

Sanitization contains killing microorganisms on a surface or object including shoe and slipper soles. The goal of sanitization is not to completely eliminate all microbes, but to reduce them to a level that will reduce the potential for an infection to occur. Shoe and slippers sole should be cleaned before being sanitized. If cleaning is not done prior to sanitizing, the sanitizer might not be as effective. This is because dirt, dust, and other material can inhibit the sanitizer’s contact with the object. Sanitizers must be in contact with a surface or object for a certain amount of time (called “dwell” time) in order to more effectively kill certain microbes. In general, sanitizers do not kill as many microbes as

disinfectants, but sanitizers are safer for contact with skin and for mouthing.

**On Disinfection**

Like sanitization, cleansing also involves killing microbes on a surface or object. While disinfectants generally kill more microbes than sanitizers, disinfectants do not completely eliminate all microbes from a surface or object. They minimize presence of microbes making it safer for human contact. For disinfectants to work properly, the area and sanitizing ramp should be cleaned first. This reduces inhibition of the disinfectant by soil or other organic material. As with sanitizers, the amount of time the disinfectant is in contact with the surface is important to be more effective to reduce microbes. The smart shoe/slippers sanitizing ramp in this study, was patterned to already existing several shoe cleaning devices which can be sorted into the following identified categories:

1. Simple dry mats where shoes are wiped as with the common entry door mat. (Tai, Stull, Kafka *et al.*, and WO9631193);
2. Dry sticky mats that provide a surface that removes debris from the soles of shoes by adhesion with liquid spray system and,
3. Wet mats that generally have a liquid material in all or a part of the mat.

The present sanitizing ramp, a mist sprayer of a sanitizing solution is positioned at the bottom of the ramp so that each spraying event is initiated by a foot pedal acting switch that spray the solution onto a portion of the steeper.

**Table 1:** Material and Cost

Qty	Unit	Name & Description	Unit Cost	Total Cost
2	Pcs	1/2” diameter galvanized pipe schedule 20	450.00	900.00
1	pc	Round bar, smooth #8	75.00	75.00
1	pc	Angle bar 1” X 1” X ¼”	350.00	350.00
3	pcs	Push button switch (heavy duty)	50.00	150.00
1	pc	Fusible link, 20Amp	50.00	50.00
1	set	11MWater Mist Spray Electric Diaphragm Pump assembly (with Misting line, Brass Mist Nozzle and AC Adapter	3,000.00	3,000.00
1	pc	12V DC High pressure Agricultural Electric Water Pump Water Sprayer Pump, 130 psi (8.3 Bar Cut off), 4-7 Amps, Open flow-10-12LPM	2,500.00	2,500.00
1	pc	12V Full wave Converter Charger Input-220V AC, Output-12v DC, Rating-12Amps	3,000.00	3,000.00
4	pcs	Steel caster	125.00	500.00
1	pc	Stainless steel sheet #20 (Flat Sheet)	3,000.00	3,000.00
2	kilos	Welding Rod AWS E-6013	150.00	300.00
2	kilos	Stainless Welding Rod AWS E-308-16	250.00	500.00
12	pcs	Bolts and nuts 3/8” X 1”	15.00	180.00
6	m	Auto Wire # 14	150.00	150.00
1	pc	Water jug, 1gallon capacity	300.00	300.00
3	m	Flexible hose 2/8” diameter	250.00	250.00
		Labor Cost		3,500.00
<b>Total</b>		<b>Material cost + labor cost</b>		<b>18,705.00</b>

As support, a resilient base mat served as a moisture-absorbent fabric and slipper/shoe cleaner before and after stepping on the sanitizing ramp. Above table shows that the total cost is PHP18,705.00 per budget appropriation and its total weight is 10 kilograms considered portable.

**Technical Description of the Device:**

The sanitizing ramp for smart shoes/slippers consists of the following components.

1. Mainframe-it contains all the parts necessary to perform the sanitizing ramp.
2. Storage tank- is used for storing disinfectant liquid.
3. Pump assembly- a means of pressurizing the disinfectant liquid.
4. Connecting hose and pipes - for connecting the spray head to the pump and spraying jug.
5. Nozzles – it is designed for applying disinfectant to shoes or slippers.
6. Foot steeper-automatically switches the pump to supply sanitizing vapor.
7. Power source- used for powering up the disinfectant pump.

8. Collection basin- a large drain placed below the ramp to catch excess atomized sprays.

9. Hand sanitizer-additional sanitizing device for hand only

Note: The above parts are assembled which gives an option to be transported from one place to another Below is the orthographic view of the sanitizing ramp.

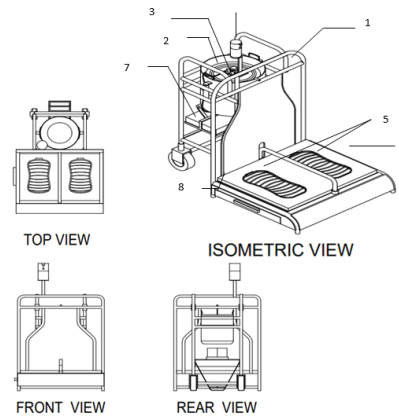

**Figure 4:** Orthographic view of the Sanitizing Ramp.

**Table 2:** Technical capacity specification of the components.

No	Component	Technical Specifications
1	Pump Assembly	60-70 psi
2	Misting Nozzle	49-89 cc/min
3	Power source	12V
4	Frame Assembly: a) Main Frames b) Storage and Pump frame	12”H X 4” W X 4” L
5	Disinfectant Storage Unit	1-gallon capacity

Above table specifies the necessary technical specifications of the sanitizing ramp.

**Table 3:** Recommended nozzle size used in the sanitizing ramp

Orifice	Flow	Min. Pressure	Application
0.381mm (.012")		60 psi	Cooling people in areas with extreme heat and low humidity or where the nozzles are placed high above the area to be cooled.
0.4mm (.016")	High	60 psi	Outdoor applications
0.5mm (.020")	Very High	60 psi	Special Effect

The information in table 3 displays the minimum line pressure needed for the device, the suggested and usual nozzle sizes, and the anticipated flow rate. The project’s nozzle tip was .5mm, or.020 of an inch, to achieve the desired atomized spray.

**Table 4:** Nozzle size and spray quantity

Diameter of hole (mm)	Working Pressure (kg/m)	Spray Quantity (cc/min)	Spray Angle (degrees)	Application
0.3	20-70	10-20	65-75	Outdoor
0.4		20-46	80	
0.5		49-89	80	

Table 4 lists the various misting nozzle sizes that were tested, including those with holes that were 0.3, 0.4, and 0.5 millimeters in diameter. Based on the spray pattern, spray angle, and application it creates, it was determined that 0.5mm is the best nozzle hole for the sanitizing ramp. The greatest size of shoes or slippers subjected to sanitation can be covered by the misting nozzle. The mister nozzles’ (0.5mm) delivery of very small droplets of disinfection liquid at a high pressure of 2 bar range in size from 49 to 89 cc.

Figure 4 shows the general structural layout of the smart shoe/slipper sanitizing ramp. Table 2 contains the technical details. The sanitizing liquid is dispensed from the nozzle at a flow rate of 0.20 Liter per minute (LPM) as described in the specification of a 0.20mm nozzle. The misting nozzles were positioned around the main frame assembly's perimeter. Spray is immediately directed towards the surface of the shoe or slipper that has to be cleaned. Sanitizing ramps are portable because they weigh only 5 kg when empty and 15 kg when empty with the pump and storage component attached. A 0.6m length tube connects the misting nozzle, which has a weight of

about 0.15 kg, to the pump. Figure 5 shown above is the schematic diagram of the sanitizing ramp which serves as basis in the development of the device. According to Table 5, the gadget employed a mixture of 70% alcohol and 30% water and sprayed at a rate of 0.2 liter per

**Table 5:** Disinfectant chemical composition

	Mixture	Squirt per second
Disinfectant composition (WHO approved)	70%alcohol & 30% water	<0.2 liter per min (LPM)

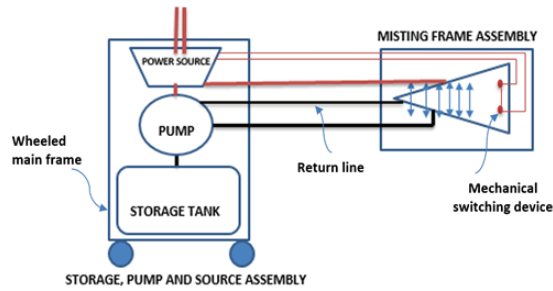

**Figure 5:** Schematic diagram of the smart shoe/slippers sanitizing ramp.

minute (LPM). According to WHO health findings, this mixture can already kill 99.9% of bacteria. Any type of disinfection liquid, including neutral sanitizing liquid in accordance with WHO criteria or as allowed by national regulatory bodies, may also be used, depending on its efficacy and accessibility. Two push buttons on the top of the spray head, which are shown in a schematic flow in Figure 6, are used to activate and start the disinfectant spray. It is simple to use or replace a collection basin that is situated below the sanitizing ramp for cleaning needs. The cost analysis was done by comparing the specifications of the sanitizing ramp with the two models



**Figure 6:** Wiring installation and testing of the shoe/slippers sanitizing ramp.

**Table 6:** Cost Analysis Results

Function	Model 1 Php18,705.00 Shoe/slippers sanitizing ramp	Model 2 Php 18,657.60 Stainless Steel Hand Sanitiser Dispenser	Model 3 157,953.54+tax Smart Step Footwear sanitizing unit
Purpose	For sanitizing shoe/slippers	For sanitizing hand	For sanitizing footwear
Operation	Foot operated	Foot operated	sensor operated
Max no. of user	1 at a time	1 at a time	1 at a time
Transportability	Portable	portable	portable
Sanitizer that operates in seconds	In seconds	In seconds	6-8 minutes
Sanitizing storage liquid capacity	4 liters	3.6 liters	n/a
Safety switch that limits the spray	Foot pedal press	Foot pedal press	Infra-red sensor
Built	Combined galvanized and stainless	stainless	plastic

of commercially available ones (Stainless Steel Hand Sanitiser Dispenser and Smart Step Footwear sanitizing unit). The cost analysis result is shown in Table 4.

### On Applications

#### Operation

This project development study uses the pressure-swirl atomizer. The electrically actuated in-tank pressure pump accelerates the sanitizing liquid through a mister nozzle into the shoe and slippers sole. The provided mister nozzle is a precision device that facilitates dispersion of liquid into a spray.

When the main control switch is turned on, the disinfectant sanitizing pump is activated for several seconds to prime the misting injectors. The pump automatically activated when someone steps on the sanitizing ramp on both feet and deactivates when any of the feet is removed from the ramp which cause the stoppage of the misting.

The sanitizing apparatus for shoe and slipper has been reinforced with a base mat and a top mat of a moisture absorbent fabric. The reservoir holds the main pump assembly that contains sanitizing mixture and an electrically-operated switch deliver a fine spray. The shoe or slippers soles are wiped on the base mat and dried on a dry portion of the mat.

This smart shoe/slipper sanitizing ramp has been designed and fabricated keeping the following applications of the device in mind to help disinfect the riding public, people entering hospitals, hotels, office premises, restaurants, malls shops and markets goers.

#### Evaluation

The proponents performed a user's acceptance evaluation for the shoe and slipper sanitizing ramp using a survey questionnaire involving 30 student-trainees and other respondents just in time for the opening of classes.

Seven (7) questions were prepared to evaluate the sanitizing ramp: (1) the sanitizing ramp is easy to use; (2) it sprays smoothly; (3) the atomizer nozzle works properly; (4) the mechanical switching mode works properly; (5) the main frame can stand different weights (6) The mechanical switch is effective for controlling wastage of sanitizing liquid, and (7) all the parts of the sanitizing ramp are functioning. Each question was rated using the following Likert scale: 4.5-5.0 equals excellent; 3.5-4.49 equals satisfactory; 2.5-3.49 equals fair; 1.5-2.49 equals needs improvement; and 1-1.49 equals poor. The overall mean for the performance of the shoe/slipper sanitizing ramp is 3.5286.

#### Findings

While using the sanitizing ramp, flow rate was negatively affected by factors easily overlooked during testing and diagnosis. Considering everything that is required to create a consistent flow rate and found the following items that contribute to it.

1. Low fuel pump voltage, poor circuit integrity, faulty

connection, weak battery and defective fuel pump relay keep the pump from operating normally. So, a need to check both the 12V supply and the ground sides of the electrical system to ensure proper function.

2. Defective pressure regulator. It is a must to ensure that pressure regulator shows no signs of leakage or internal failure. This will bring great effect on the performance of the sanitizing ramps.

3. Low sanitizing fluid supply. Keeping sanitizing fluid level well above the level of the feed pump intake – minimum 1/4 full is normally a reliable estimate.

4. Poorly functioning fluid filter. Filters are designed to catch impurities before allowing sanitizing fluid to flow into the squirting/misting unit below the ramps. A dirty or even poor-quality filter can decrease or even stop fuel flow.

5. Defective sanitizing fluid lines. A need to look for fuel line leakage or collapsed/ damaged fuel line sections to ensure continues operation of the fluid system.

### CONCLUSION

The coronavirus is one of the most common viruses in the world today, but the best way to deal with it is to prevent it from ever occurring in the first place. By now, we've all learned how to deal with the virus—wash our hands, stay home when ill, avoid traveling when possible, and wash our hands. The project study was fixated on a manual machine that reveals implementing intervention actions through a sanitizing ramp to help prevent the spread of pathogenic agents and unknown viruses. The conclusions were drawn based upon the results of this project development study. The sanitizing apparatus for shoe and slipper soles was still provided with a resilient base mat-assist to serve as moisture-absorbing fabric. The reservoir contains a sanitizing solution and a foot-actuated spray mechanism. The soles of shoes and slippers are dried by wiping them on a dry section of the mat provided. The proponents designed the disinfection sanitizing ramp through a pump-nozzle that sprays sanitizing liquid from below the foot based on the simplest possible design. This device uses a pump-nozzle assembly for spraying the disinfectant, with the option to be enhanced by combining with Ultra Violet (UV) radiation and the possibility of adding hot pressurized air to increase the virus-kill efficiency. Based on the results gathered throughout the study, it can be concluded that a shoe and slipper sanitizing ramp has been successfully developed.

Through testing and evaluation with student respondents' having different shoe sizes, the overall performance of the sanitizing ramp is satisfactory. Its performance is equivalent to that of the commercially available sanitizing devices but is less costly and easy to maintain. Some identified recommendations for further improvement of the sanitizing ramp are: integration of hot pressurized air, combination with UV rays, and inclusion of an infrared human temperature sensor. Using recently available apps, it will be possible to secure strong germs or virus kill.

## REFERENCES

- Allen, K. P., Csida, T., Leming, J., Murray, K., & Thulin, J. (2010). Efficacy of footwear disinfection and shoe cover use in an animal research facility. *Lab animal*, 39(4), 107-111. <https://doi.org/10.1038/labon0410-107>
- Boyce, J. M. Modern technologies for improving cleaning and disinfection of environmental surfaces in hospitals. *Antimicrob Resist Infect Control* 5, 10 (2016). <https://doi.org/10.1186/s13756-016-0111-x>.
- Cantrell, Susan. (2019). *Preventing infection from surface to stratosphere*. Retrieved from <https://www.hpnonline.com/infection-prevention/article/21111201/preventing-infection-from-surface-to-stratosphere>
- Kumar, D., Sonawane, U., Gohil, M. K., Pol, R., Patil, A. S., Mittal, R., & Agarwal, A. K. (2020). Design and Development of a Portable Disinfectant Device. *Transactions of the Indian National Academy of Engineering*, 5(2), 299–303. <https://doi.org/10.1007/s41403-020-00138-2>
- Eske, J. (2020, April 17). How to disinfect shoes. Medically reviewed by Debra Rose Wilson, Ph.D., MSN, R.N., IBCLC, AHN-BC, CHT. <https://www.medicalnewstoday.com/articles/how-to-disinfect-shoes#why-is-it-important>
- Miller, R., Simmons, S., Dale, C., Stübich, M., & Stachowiak, J. (2015). Utilization and impact of a pulsed-xenon ultraviolet room disinfection system and multidisciplinary care team on clostridium difficile in a long-term acute care facility. *Am. J. Infect. Control*. 43, 1350–3.
- Mondal, I., Molla, J. A., Karmakar, S. & Masum, H. (2022). Design of a smart footwear disinfecting station for crowded premises. *Proceeding of International Conference on Industrial Automation and control*. pp 307-318
- Rutala, W. A, Weber, D. J. (2013). Disinfectants used for environmental disinfection and new room decontamination technology. *Am. J. Infect. Control*. 2013, 41, S36–41.
- Rashid, T., Poblete, K., Amadio, J., Hasan, I., Begum, K., Alam, M. J., & Garey, K. W. (2018). Evaluation of a shoe sole UVC device to reduce pathogen colonization on floors, surfaces and patients. *Journal of Hospital Infection*, 98(1), 96-101. <https://doi.org/10.1016/j.jhin.2017.10.011>
- Shailesh. S. S., Akash, N. B., Gaurav, N. P., Rahul, R. P., Devrao, S. K., Aniket, D. R., & Ritesh, B. (2021). Shoe sanitization machine. *International Journal of Research in Engineering, Science and Management*, 4(6)
- Yusuf, Y. Y., Ahmed, A. H., Abubakar, A. B., Yusuf, Y. B., Abdoulie, B., Yau, A. S., & Farida, Y. B. (2022). Web Mapping for Nigeria Covid-19 Testing and Vaccination Site Finder Application. *American Journal of Multidisciplinary Research and Innovation*, 1(3), 43-51. <https://doi.org/10.54536/ajmri.v1i3.348>